

DOUBLE 360 DEGREE TURN

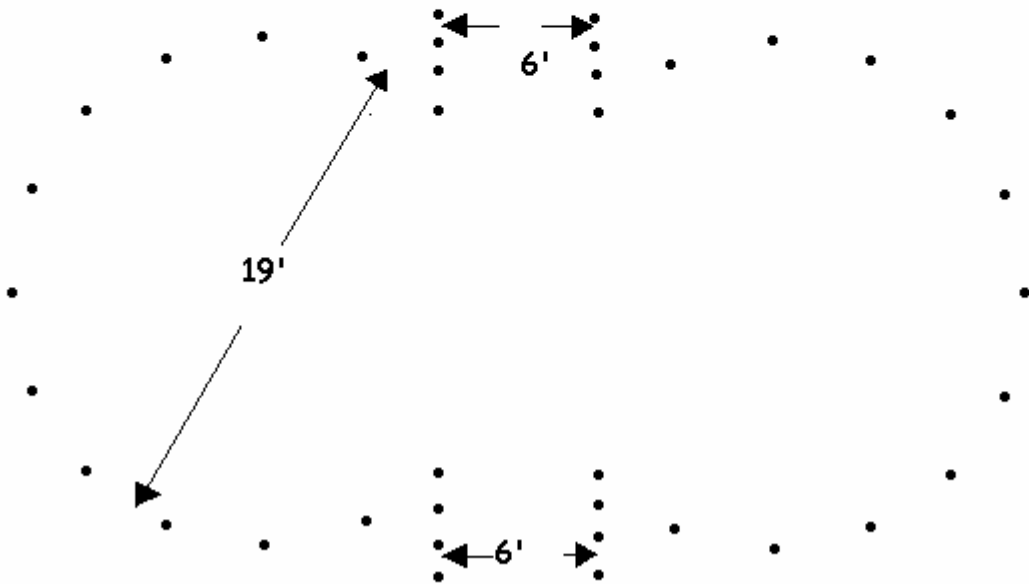

The Harp

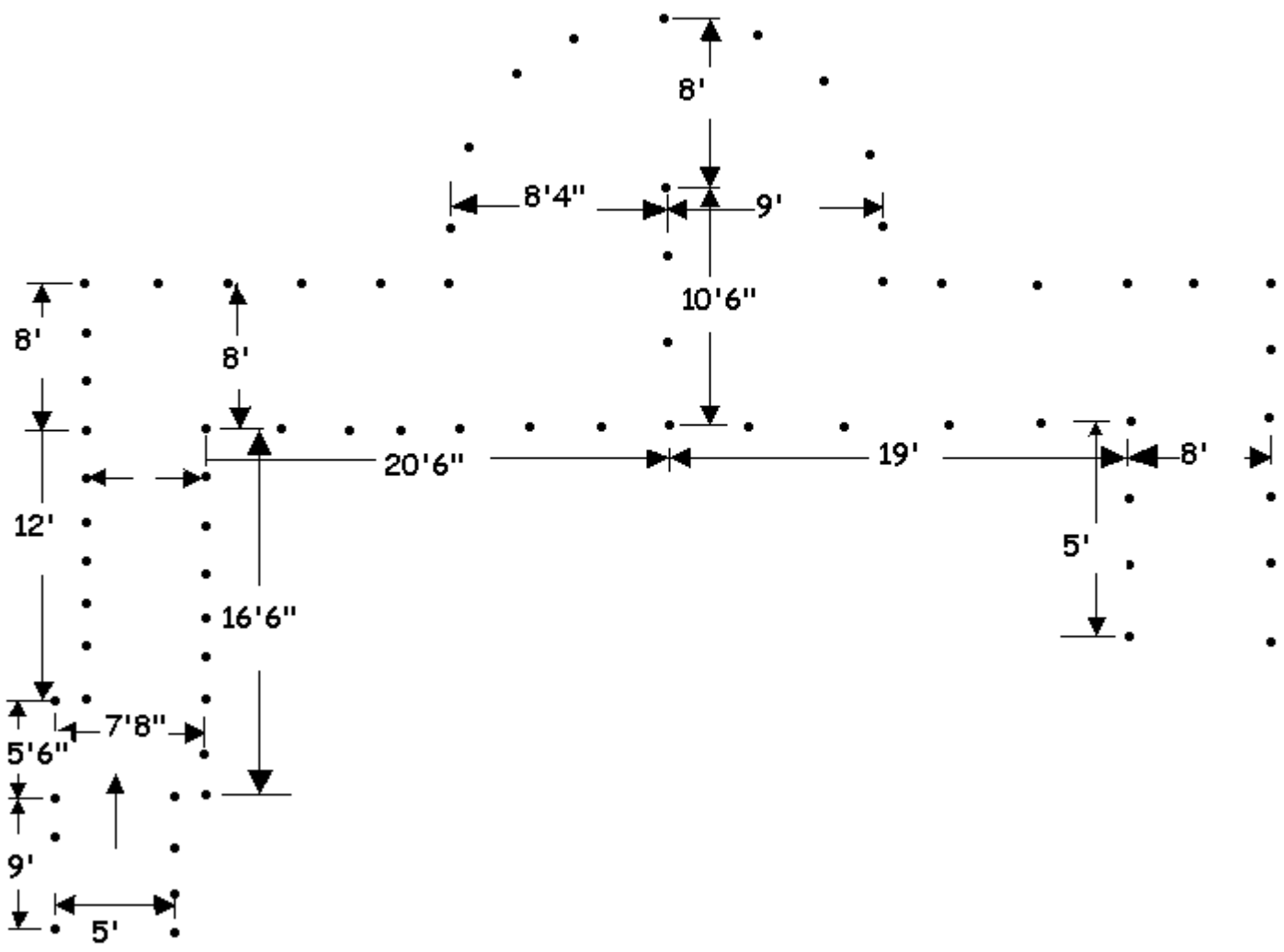

Obstacle Course Lane Change

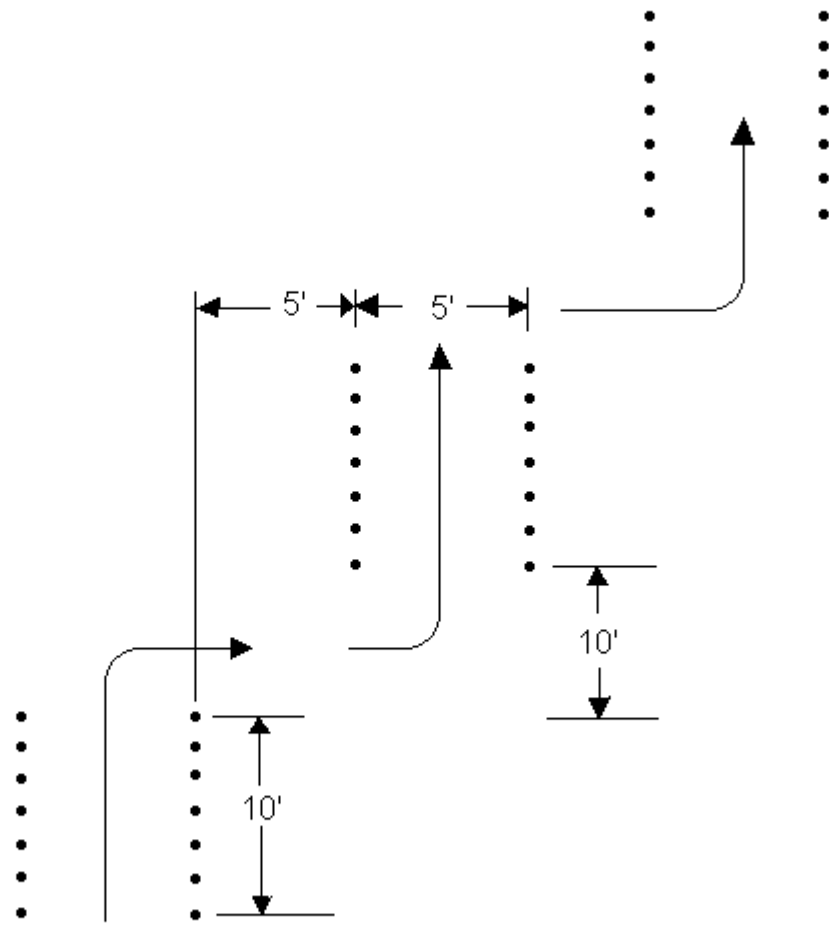

Slow Cone Weave

Note: Diagram depicts 6 cones,
however, more may be used
depending on need.

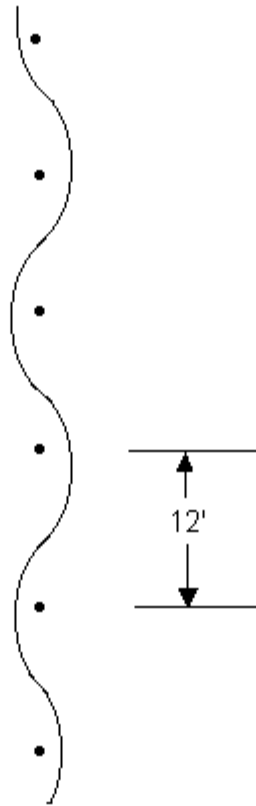

90 Degree Turn

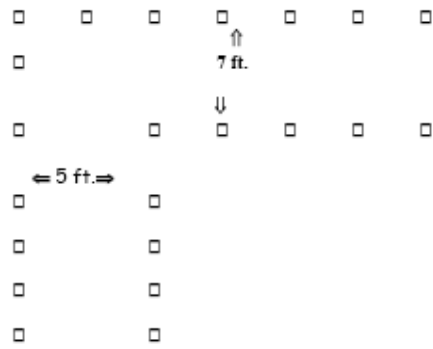

DOUBLE 360 DEGREE TURN

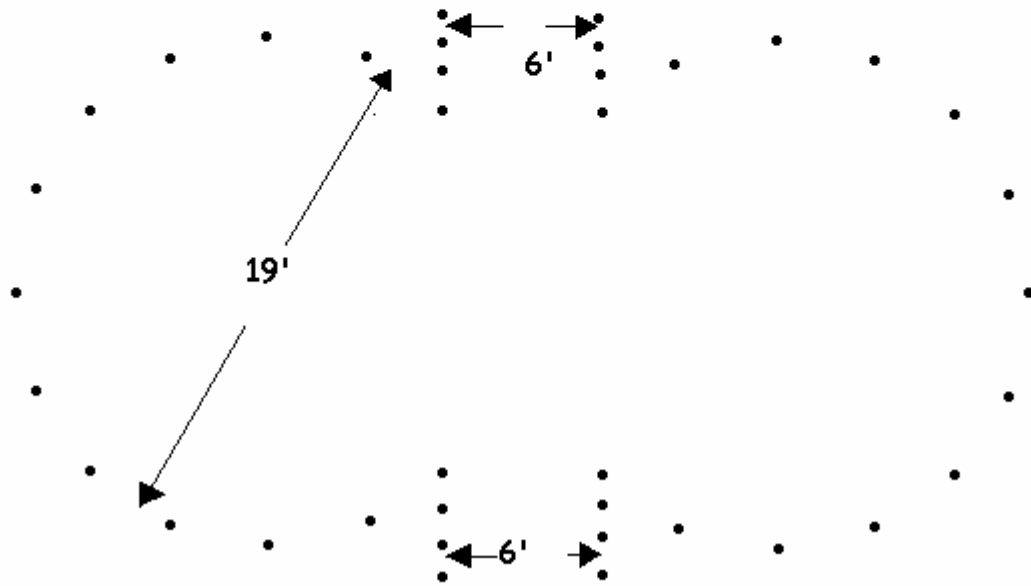

140 Degree Pullout

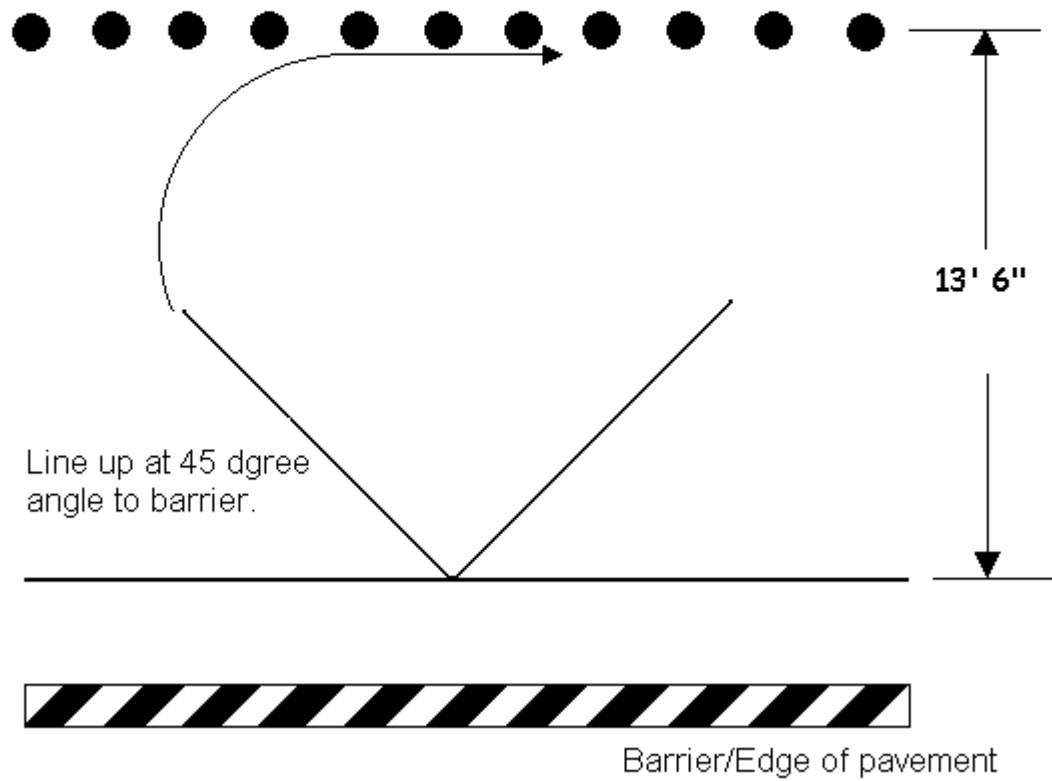

Snowman

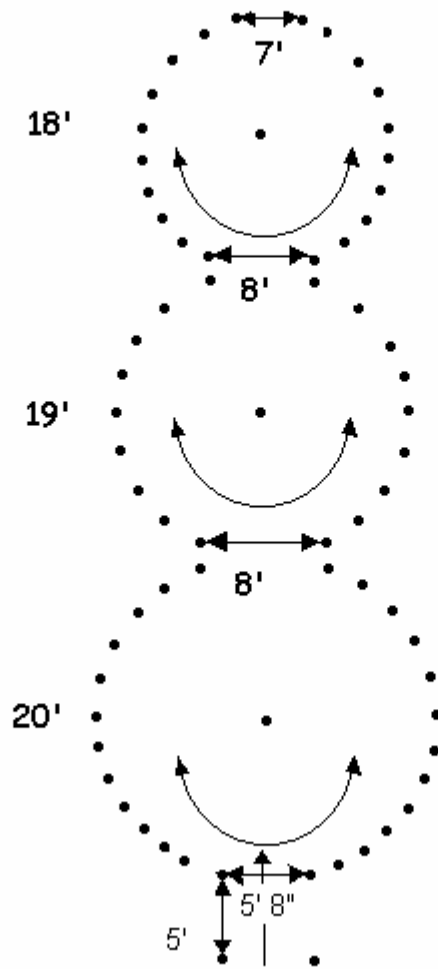

360 Degree Circle

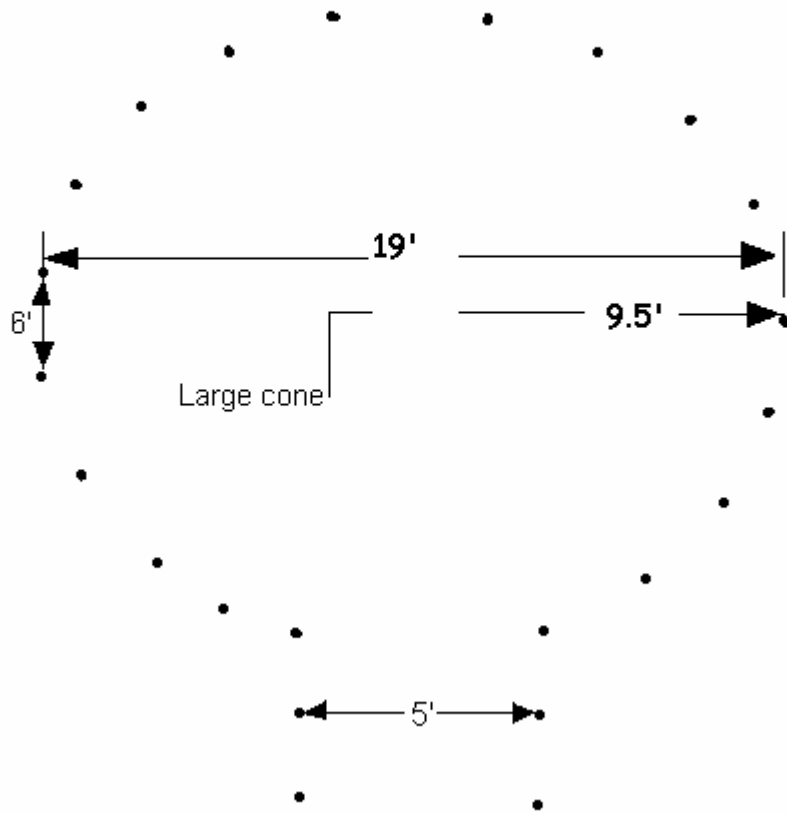

Offset Cone Weave

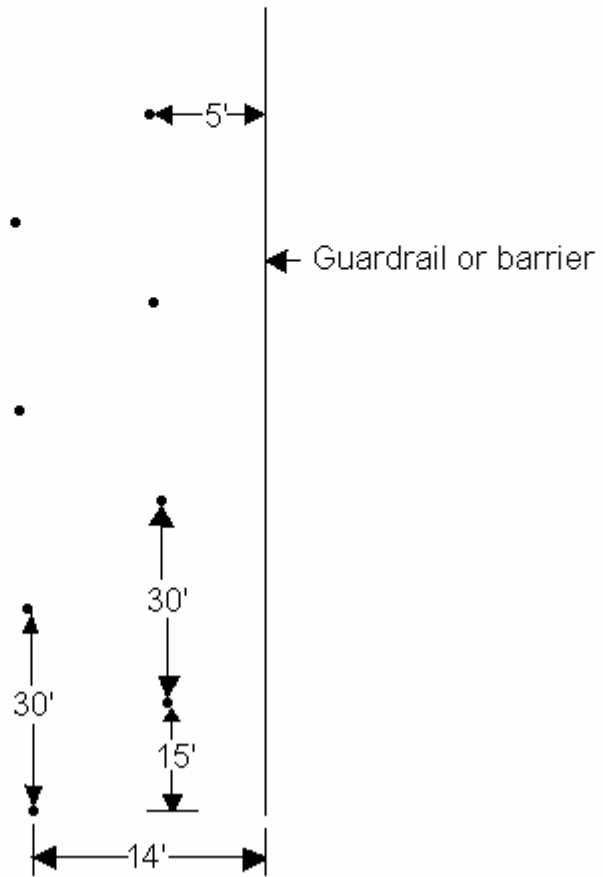

INTERSECTION

